

# Fini<sup>®</sup>Long

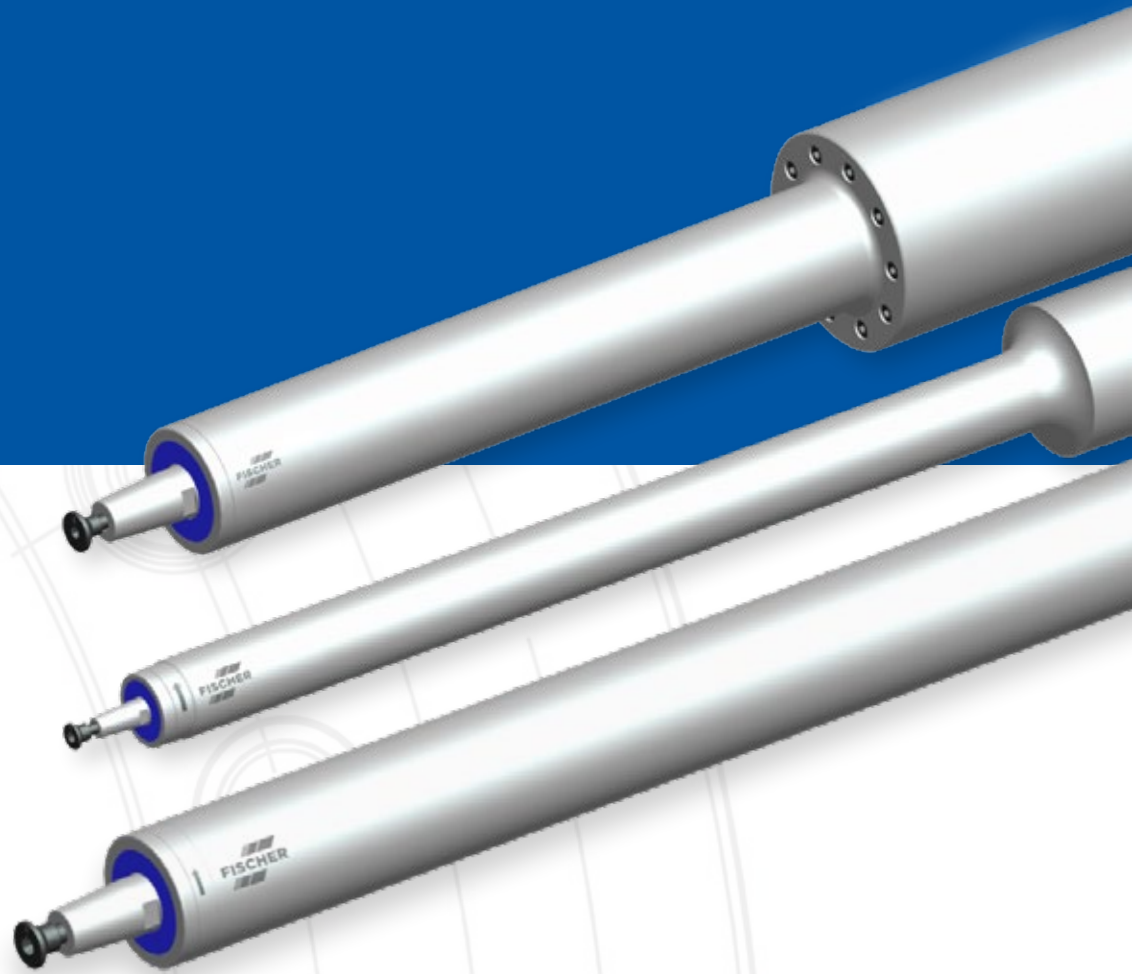

FISCHER Tieflochschleifspindeln  
*FISCHER deep hole grinding spindles*

# Fini<sup>®</sup>Long – M34-Baureihe

## Fini<sup>®</sup>Long – M34 series

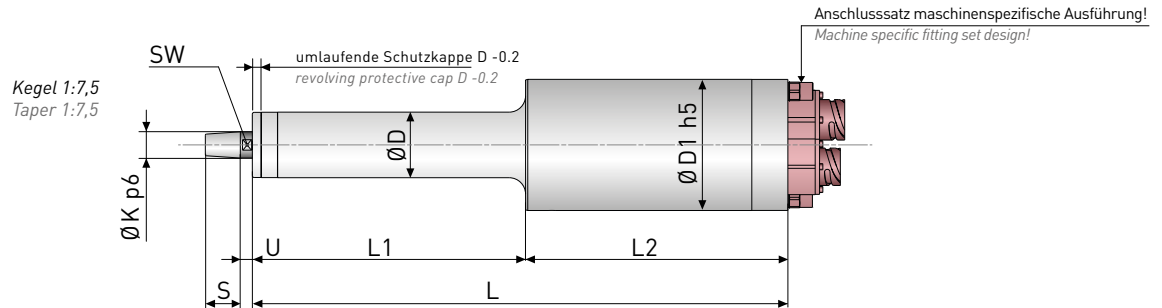

Bezeichnung / Description			Abmessungen / Dimensions							Max. Drehzahl <sup>(1)</sup> Max. Speed [1]	Max. Leistung Max. Power	Option Options
Typ Type	D. D1		L	L1	L2	K	S	U	SW	min <sup>-1</sup> / [rpm]	kW (S1)	Drehgeber shaft encoder
M34-FAVY	25.120	R	468	200	268	9	15	6	8	20'000	1.2	—
M34-FAVY	25.120	R	568	300	268	9	15	6	8	20'000	1.2	—
M34-FAVY	25.120	R	698	430	268	9	15	6	8	20'000	1.2	—
M34-FAVY	32.120	R	568	300	268	9	15	6	8	20'000	1.2	—
M34-FAVY	32.120	R	668	400	268	9	15	6	8	20'000	1.2	—
M34-FAVY	36.120	R	440	220	220	11	18	6	9	20'000	3,0	0
M34-FAVY	36.120	R	520	300	220	11	18	6	9	20'000	3,0	0
M34-FAVY	36.120	R	600	380	220	11	18	6	9	20'000	3,0	0
M34-FAVY	42.120	R	600	380	220	11	18	6	9	20'000	3,0	0
M34-FAVY	42.120	R	690	470	220	11	18	6	9	20'000	3,0	0
M34-FAVY	42.120	R	920	700	220	11	18	6	9	20'000	3,0	0
M34-FAVY	50.120	R	490	250	240	16	25	8	14	20'000	4,0	0
M34-FAVY	50.120	R	570	350	220	16	25	8	14	20'000	3,0	0
M34-FAVY	60.120	R	490	250	240	24	32	11	22	12'000	4,0	√
M34-FAVY	60.120	R	540	300	240	24	32	11	22	12'000	4,0	√
M34-FAVY	60.120	R	620	380	240	24	32	11	22	12'000	4,0	√
M34-FAVY	60.120	R	690	450	240	24	32	11	22	12'000	4,0	√
M34-FAVY	60.120	R	740	500	240	24	32	11	22	12'000	4,0	√
M34-FAVY	80.120	R	760	520	240	34	45	13	30	12'000	4,0	√
M34-FAVY	100.120	R	590	350	240	34	45	13	30	12'000	4,0	√
M34-FAVY	100.120	R	620	380	240	34	45	13	30	12'000	4,0	√

↙ Drehrichtung R  
 Bestellbeispiel: M34-FAVY25.120R468  
 Rotation R  
 Order example: M34-FAVY25.120R468

rechts/right

<sup>(1)</sup> Ohne Werkzeug – je nach Werkzeugabmessung und -gewicht ist die max. Betriebsdrehzahl zu reduzieren!  
 Alle Abmessungen in mm.

<sup>(1)</sup> Without tool – depending on tool design and weight the maximum operating speed may be reduced!  
 All dimensions in mm.

√ Option lieferbar in Verbindung mit Intercontec-  
 Steckverbinder M23 (Siemens kompatibel)

√ Option available in conjunction with Intercontec  
 connector M23 (Siemens compatible)

0 Option auf Anfrage  
 — Option nicht lieferbar

0 Options on request  
 — Options not available

Passendes Zubehör finden Sie in separaten Datenblättern.  
 Suitable accessories can be found in separate data sheets.

# Fini®Long – FAV-Baureihe mit abgesetzter Spindelhülse

## Fini®Long – FAV series with stepped spindle housing

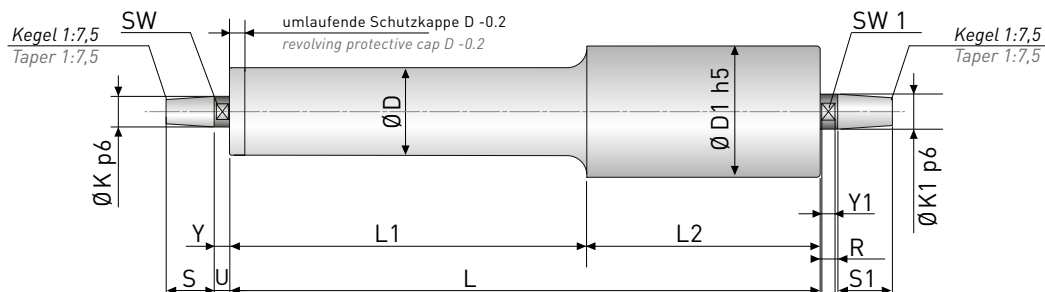

Bezeichnung / Description			Abmessungen / Dimensions													Max. Drehzahl <sup>(1)</sup> Max. Speed <sup>(1)</sup>
Typ Type	D. D1		L	L1	L2	K	K1	S	S1	U	Y	Y1	R	SW	SW1	min <sup>-1</sup> / [rpm]
FAV	25.60	R	335	175	160	9	16	15	25	6	4.5	6.5	8	8	14	24'000
FAV	25.60	R	450	290	160	9	16	15	25	6	4.5	6.5	8	8	14	25'000
FAV	25.60	R	530	370	160	9	16	15	25	6	4.5	6.5	8	8	14	25'000
FAV	28.80	R	530	290	240	9	16	15	25	6	4.5	6.5	8	8	14	23'000
FAV	28.80	R	630	390	240	9	16	15	25	6	4.5	6.5	8	8	14	23'000
FAV	32.80	R	530	290	240	9	16	15	25	6	4.5	6.5	8	8	14	20'000
FAV	32.80	R	630	390	240	9	16	15	25	6	4.5	6.5	8	8	14	20'000
FAV	36.80	R	530	290	240	11	16	18	25	6	4.5	6.5	8	9	14	18'000
FAV	36.80	R	630	390	240	11	16	18	25	6	4.5	6.5	8	9	14	18'000
FAV	42.80	R	630	390	240	11	16	18	25	6	4.5	6.5	8	12	14	15'000
FAV	50.80	R	530	290	240	16	16	25	25	8	6.5	6.5	8	14	14	13'000
FAV	50.80	R	630	390	240	16	16	25	25	8	6.5	6.5	8	14	14	13'000
FAV	60.80	R	700	460	240	24	24	32	32	11	8.5	8.5	11	22	22	11'000
FAV	80.100	R	800	560	240	34	34	45	45	13	11	11	13	30	30	8'000
FAV	90.100	R	900	660	240	34	34	45	45	13	11	11	13	30	30	7'000
FAV	100.120	R	1000	700	300	48	48	65	65	13	11	11	13	41	41	6'500
FAV	110.120	R	1200	900	300	48	48	65	65	13	11	11	13	41	41	6'000

↙ Drehrichtung R

Bestellbeispiel: FAV25.60R335

Rotation R

Order example: FAV25.60R335

rechts/right



<sup>(1)</sup> Ohne Werkzeug – je nach Werkzeugabmessung und -gewicht ist die max. Betriebsdrehzahl zu reduzieren!

<sup>(2)</sup> Alle Abmessungen in mm.

<sup>(1)</sup> Without tool – depending on tool design and weight the maximum operating speed may be reduced!

<sup>(2)</sup> All dimensions in mm.

Passendes Zubehör finden Sie in separaten Datenblättern.  
Suitable accessories can be found in separate data sheets.

# Fini®Long – FAV-Baureihe mit zylindrischer Spindelhülse

## Fini®Long – FAV series with cylindrical spindle housing

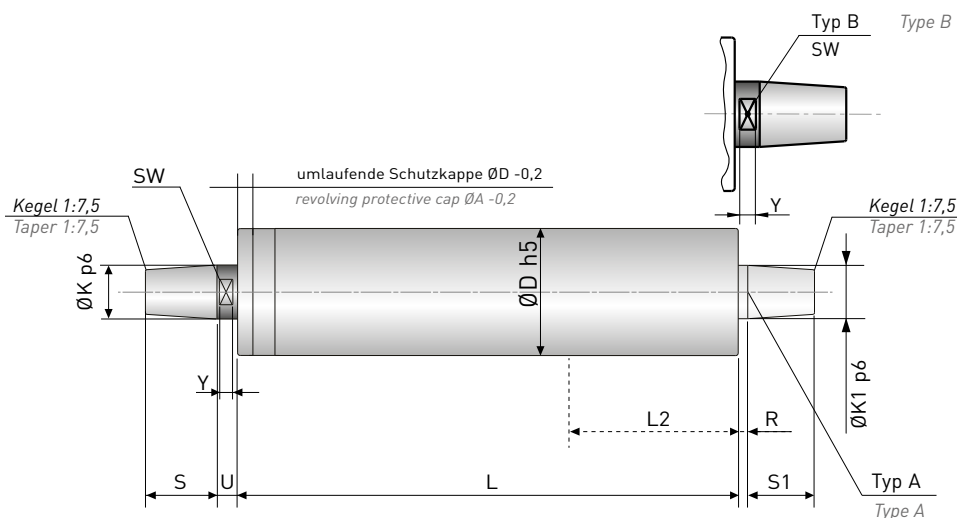

Bezeichnung / Description				empfohlene minimale Spannlänge recommended minimal Clamping length		Abmessungen / Dimensions								Max. Drehzahl <sup>(1)</sup> Max. Speed <sup>(1)</sup>
Typ Type	D	R	L	L2	Typ	K	K1	S	S1	U	Y	R	SW	min <sup>-1</sup> / [rpm]
FAV	36	R	355	80	B	11	11	18	18	6	4.5	6	9	18'000
FAV	40	R	400	80	A	14	13.6	22	19	7	5.5	10	12	16'000
FAV	45	R	400	90	A	14	13.6	22	19	7	5.5	10	12	16'000
FAV	50	R	400	100	B	16	16	25	25	8	6.5	8	14	16'000
FAV	50	R	500	100	B	16	16	25	25	8	6.5	8	14	12'000
FAV	60	R	500	120	B	24	23.6	32	29	11	8.5	14	22	16'000
FAV	60	R	630	120	B	24	24	32	32	11	8.5	11	22	16'000
FAV	80	R	500	160	A	34	34	45	45	13	11	13	30	17'000
FAV	80	R	630	160	B	34	34	45	45	13	11	13	30	12'000
FAV	80	R	800	160	B	34	34	45	45	13	11	13	30	12'000
FAV	100	R	630	200	A	48	48	65	65	13	11	3	41	10'000
FAV	100	R	1000	200	B	48	48	65	65	13	11	13	41	6'000
FAV	100	R	1250	200	B	48	48	65	65	13	11	13	41	6'000
FAV	120	R	800	240	B	54	54	72	72	13	11	13	46	7'000
FAV	120	R	1250	240	B	54	54	72	72	13	11	13	46	5'000

↙ Drehrichtung R  
Bestellbeispiel: FAV36R355  
Rotation R  
Order example: FAV36R355



<sup>(1)</sup> Ohne Werkzeug – je nach Werkzeugabmessung und -gewicht ist die max. Betriebsdrehzahl zu reduzieren!

<sup>(2)</sup> Alle Abmessungen in mm.

<sup>(1)</sup> Without tool – depending on tool design and weight the maximum operating speed may be reduced!

<sup>(2)</sup> All dimensions in mm.

Passendes Zubehör finden Sie in separaten Datenblättern.  
Suitable accessories can be found in separate data sheets.

## Fini®Long – M34-Baureihe

Alle Motorspindeln garantieren rundum optimale Lauf-  
ruhe, maximale Drehzahl und höchste Präzision. Das  
Kupplungswellenprinzip als bewährtes Konstruktions-  
merkmal bietet unübertroffene Ergebnisse auch bei  
schwierigen Bearbeitungsaufgaben in tiefen Bohrungen.

- Hochleistungs-Präzisionsschleifspindeln mit wassergekühltem Motor und Aussenkegel für das Innenschleifen von tiefen Bohrungen
- Entwickelt für radiale und axiale Belastungen
- Hochgenauigkeitsspindellager
- Lebensdauerfettsschmierung
- Labyrinthabdichtsystem mit Sperrluft
- Kegelrundlauf  $\leq 0,002$  mm
- Drehrichtung rechts
- Antrieb über Frequenzumrichter
- Durchmesser-/Längenverhältnis bis 1:20 möglich

### Optionen/Sonderlösungen:

- Manuelle HSK-Werkzeugschnittstelle
- Andere Abmessungen und Ausführungen
- Andere Motorspezifikationen
- Drehimpulsgeber

## Fini®Long – M34 series

All motorized spindles guarantee an ideal smooth running,  
maximum speed and highest precision. The coupling shaft  
principle as a proven design feature offers unsurpassed re-  
sults for difficult grinding problems in deep borings.

- High-performance precision grinding spindles with water cooled motor and external taper for internal grinding of deep boreholes
- Designed for radial and axial load
- High precision bearings
- Lifetime grease lubrication
- Labyrinth seal system with air seal
- Taper runout  $\leq 0,002$  mm
- Rotation clockwise
- Drive with frequency converter
- Diameter to length ratio possible up to 1:20

### Options/Special solutions:

- Manual HSK tool interface
- Other dimensions and designs
- Other motor specifications
- Encoder

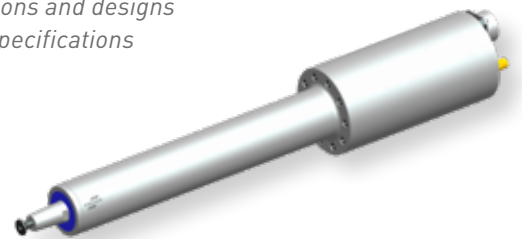

## Fini®Long – FAV-Baureihe

Diese Spindeln sind besonders geeignet zum Innen-  
schleifen von Bohrungen mit grossem Schlankheitsgrad.  
Das Kupplungswellenprinzip als bewährtes Konstruktions-  
merkmal bietet unübertroffene Ergebnisse auch bei  
schwierigen Bearbeitungsaufgaben in tiefen Bohrungen.

- Präzisions-Tieflochschleifspindeln für Riemenantrieb mit Aussenkegel
- Hochgenauigkeitsspindellager
- Lebensdauerfettsschmierung
- Labyrinthabdichtsystem
- Kegelrundlauf  $\leq 0,002$  mm
- Drehrichtung rechts
- Durchmesser-/Längenverhältnis bis 1:20 möglich

### Optionen/Sonderlösungen:

- Andere Abmessungen und Ausführungen

## Fini®Long – FAV series

These spindles are especially suitable for internal grinding of  
bores with a large slenderness ratio. The coupling shaft princi-  
ple as a proven design feature offers unsurpassed results for  
difficult grinding problems in deep borings.

- Precision deep hole grinding spindles for belt drive with external taper
- High precision bearings
- Lifetime grease lubrication
- Labyrinth seal system
- Taper runout  $\leq 0,002$  mm
- Rotation clockwise
- Diameter to length ratio possible up to 1:20

### Options/Special solutions:

- Other dimensions and designs





## Rund um die Welt / *Around the world*



**Schweiz / Switzerland**  
FISCHER AG Präzisionsspindeln  
+41 62 956 22 22  
info-fch@fischerspindle.com



**Rusland / Russia**  
FISCHER Spindle Technology  
+7 383 302 22 11  
info-fstr@fischerspindle.com



**Deutschland / Germany**  
PRECISE Technologies GmbH  
+49 2173 20535 0  
info-pt@fischerspindle.com



**USA / USA**  
FISCHER USA, Inc.  
+1 262 632 6173  
info-fusa@fischerspindle.com



**China / China**  
FISCHER SHANGHAI  
Spindle Technologies, Inc.  
+86 21 643 481 50  
info-fsh@fischerspindle.com



**Taiwan / Taiwan**  
FISCHER Taiwan Inc.  
+886 4 2312 1909  
info-ftw@fischerspindle.tw

### Autorisierte Service-Center *Authorized service-center*



**Frankreich / France**  
PRECISE France  
+33 4 50 36 90 15  
precise@precise.fr  
www.reparation-electrobroche.com



**Japan / Japan**  
CAPTAIN INDUSTRIES, Inc.  
+81 3 5674 1162  
info@capind.co.jp  
www.capind.co.jp

## Reparatur, Service & Support

Unsere Kunden unterstützen wir mit einem weltweiten Service. Hierfür stehen zusätzlich zu den produzierenden Werken der FISCHER Spindle Group auch Reparatur- und Service-Centers in Frankreich, Deutschland, USA, Russland, Japan und China zur Verfügung. Neben unseren Spindeln reparieren wir auch Fremdfabrikate.

### Unsere Kompetenzen

- Spindelreparaturen aller Marken
- Höchste Verfügbarkeit von Original-, Ersatz- und Austauschteilen
- Vor-Ort-Support
- Wartungsschulung & Applikationsberatung

Ihre Ansprechpartner vor Ort helfen Ihnen gerne weiter.

## Repair, Service & Support

*We provide our customers with worldwide service and support, for which we can call on our FISCHER Spindle Group manufacturing plants as well as repair and service centers in France, Germany, the USA, Russia, Japan and China. We not only service our own spindles but those of other manufacturers as well.*

### Our competencies

- Repair of all spindle brands
- Highest availability of original spare and replacement parts
- On-site support
- Maintenance training & application consulting

*Your on-the-spot contacts look forward to being of service.*